

# A COMPREHENSIVE DESIGN AND ANALYSIS OF BLUETOOTH CONTROLLED ROBOT

**By: Anuradha Kuraniya, M.Tech. (Ece), Faculty Of Electronics And Communication  
Engineering, Neelkanth Institute of Engineering & Technology**

**Abstract:** - In twenty first century, smart phone has become the foremost essential issue in our everyday life. robot application primarily based smart phones have become anytime a lot of powerful and equipped with many accessories that are helpful for Robots. This project describes a way to management a golem mistreatment mobile through Bluetooth communication, some options regarding Bluetooth technology, parts of the mobile and golem. we have a tendency to gift a review of golems controlled by itinerant via moving the robot upward, backward, left and right aspect by the mechanical man application like Arduino, Bluetooth. Bluetooth has changed however folks use digital device reception or workplace, and has transferred ancient wired digital devices into wireless devices. Here we have a tendency to are mistreatment Bluetooth communication, interface microcontroller and robot application. we have a tendency to are victimization Arduino code to interface the Bluetooth module with microcontroller. per commands received from mechanical man the robot motion will be controlled. we have a tendency to derived straightforward solutions to produce a framework for building robots with very low price however with high computation and sensing capabilities provided by the smart phone that's used as an impact device.

**Keywords:** Wireless, Robot, Android, Bluetooth

**Introduction:** -

## INTRODUCTION

This paper represents android application based Bluetooth controlled robotic car. Here main motto of our project is to control the car with android application. Here we use mainly Arduino UNO (ATMEGA 328P), Bluetooth module (HC-05). We interface the Bluetooth module with the system so that we can easily control the system by smart phone application. This project is more necessary to the modern society in context of spying and surveillance. The project aims in designing a Robot that can be operated using Android mobile phone. The controlling of the Robot is done wirelessly through Android smart phone using the Bluetooth feature present in it. Here in the project the Android smart phone is used as a remote control for operating the Robot. The controlling device of the whole system is a Microcontroller. Bluetooth module, DC motors are interfaced to the Microcontroller. The data received by the Bluetooth module from Android smart phone is fed as input to the controller. The controller acts accordingly on the DC motors of the Robot. In achieving the task the controller is loaded with a program written using Embedded 'C' language. Related reference articles implementing wireless control of robots have been studied as mentioned in. Still there exists a requirement of a cost-effective automation system, which will be easy to implement. An example of such a costeffective project has been proposed here.

2. System style the look of the system is unbroken as straightforward as potential. Few things like cost-effectiveness and ease in style, lowprofile structure etc. are unbroken in mind before coming up with the project. Our system aims to attain the target to style a system that may offer following functionalities with a straightforward and easy-to-use interface:

a) Develop Associate in Nursing golem application that may act as an remote of a robot.

- b) Develop a mechanism which can be useful for travel.
- c) Here the main target is on the most recent technology of golem

### 2.1. ARDUNOU UNO

Microcontroller will act as the brain of the robot. The robot movement will be decided by the microcontroller. In this system I will be using microcontroller named ARDUNOU The microcontroller is programmed with the help of the Embedded C programming. In Arduino IDE has it own programming burnt in its Read Only Memory (ROM). C program is very easy to implement for programming microcontroller.



### 2.2. Bluetooth Module (HC-05)

The Bluetooth module will act as an interface between Smartphone and microcontroller. We will be using HC-05 Bluetooth module for the system, which can be used as either receiver or transmitter. Generally our transmitter will be smart-phone and receiver will be Bluetooth module

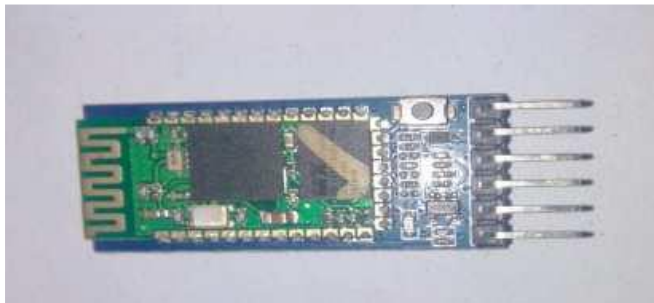

### 2.3. Android Phone

The good phone is that the transmitter of this circuit. It sends the info to microcontroller through Bluetooth module. It conjointly helps to send the instruction of forward, backward, left, right to the microcontroller. Actually, the good phone is employed as an overseas of this method. Here we tend to the Bluetooth RC Controller application (Figure 3) because the in operation remote of this method. The advantage of this project is that the appliance package designed for golem phones is unbroken straightforward however engaging with all necessary constitutional functions. The novelty lies within the simplicity of the look and functioning.



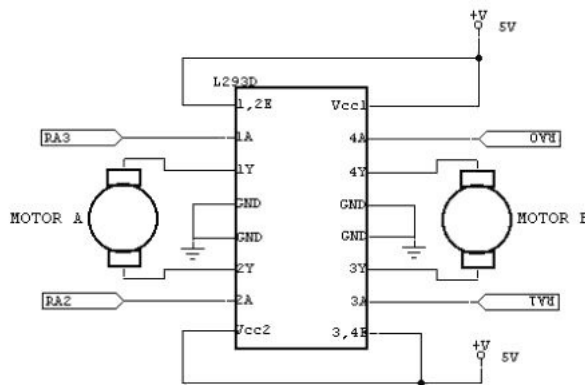

## 2.4. Motor Driver (L293D)

Motor driver IC is used to control the dc motors. It is also interfaced with the microcontroller and with circuit connections .

Hardware of this project consists of Arduino UNO, Bluetooth module and a motor driver IC. The Bluetooth module is connected with the Arduino UNO board for the reference to the user. Through the Bluetooth module for observation and dominant the actual motor reaches the board and method consequently and therefore the output of the Arduino goes to the motor driver IC and it controls the particular motor. Our projected project consists of the subsequent 3 sections:

- a) Input section
- b) Microcontroller section
- c) Output section

In our automaton application base Bluetooth controlled robotic automotive, the user interacts with the system with a wise phone. during this methodology user should be gift inside in vary (&lt; fifteen meters) to regulate the system. In future we might try and extend the vary victimisation web of Things (IoT) [12]. once user sends any knowledge to the Arduino board then the corresponding pin of Arduino goes to high state and switches the motor driver ic within the on mode. The corresponding motor moves as per the input file. Here during this project the user (android application) is that the input section. This device is connected with the Arduino board (microcontroller section) by the suggests that wirelessly i.e. Bluetooth module. The system will currently be connected with the motors (output section) to be controlled via wireless property. The circuit diagram of this project is shown below:

. Then through the info cable we tend to insert the commands within the microcontroller ATMEGA 328P. These commands facilitate the microcontroller to interface with the Bluetooth module HC- 05 and conjointly with the motor driver IC L293D. Here the Bluetooth module act as a receiver that receives the instruction from the sensible phone (remote or transmitter). Then the microcontroller decides the operation for the instruction that is returning from the sensible phone. The functions of the given directions are operated by the microcontroller. The directions are sent by the sensible phone. we will simply management the movements of the dc motor. The Bluetooth module will operate below the ten m vary, that we might try and extend in future. Here we tend to are using four twelve V, 200 R.P.M DC motors and a nine V DC battery as main power provide of this method. till we tend to send any instruction to the microcontroller the motors stay stop. once any input is given then the motors moves as per the preloaded functions within the microcontroller. Figure eight shows the snap of the entire Bluetooth based mostly sensible Phone management mechanism Project. 4.

## Conclusion

This is so an economical and economical project. The novelty lies within the indisputable fact that it's an economical project with an easy and straightforward to use interface compared to existing ones. conjointly the Bluetooth RC Controller application is additional user friendly. The mechanism is tiny in size therefore it are often employed in spying purpose. With few additions and modifications, this mechanism are often employed in army for sleuthing and disposing hidden land mines. The mechanism are often used for police work. In future we will interface sensors to the present mechanism so it can monitor some parameters and that we can improve the potency victimisation web of Things (IoT) technology. we will conjointly add wireless camera, so as to include alternative security measures.

## References

- [1] Xiaoluet.al. "Robot management style supported smartphone." management and call Conference (CCDC), 2013 25thChinese. IEEE, 2013.
- [2] Yeon-Gyunkim et.al. "Smartphone-controlled user line of work system for a mobile mechanism."Robotics (ISR), 2013 forty fourth International conference on. IEEE, 2013.
- [3] Rouanet, Pierre, et.al. "The impact of human– mechanism interfaces on the training of visual objects." AI, IEEE Transactions on twenty nine.2 (2013): 525-541.
- [4] Tatiana Alexenko et.al. "Android-based speech process for eldercare AI." Proceedings of the companionpublication of the 2013 international conference on intelligent user interfaces companion. ACM, 2013.
- [5] M. Young, The Technical Writer's vade mecum. Mill depression, CA: University Science, 1989. [6] <https://developer.android.com/training/basics/firstapp/index.html>
- [7] <https://www.codeproject.com/Articles/628894/Learn-How-to-Develop-Android-Application> [8] <https://www.tutorialspoint.com/android/>
- [9] <http://www.coreservlets.com/android-tutorial/>
- [10] Arpit Sharma, ReeteshVerma, Saurabh Gupta and Sukhdeep Kaur Bhatia, "Android Phone Controlled mechanism victimisation Bluetooth", International Journal of Electronic and engineering. Volume 7, range five (2014), pp. 443-448
- [11] A. Sharma, J. Mondal, C. Pandey, R. Kumar and A. Bhattacharya, "IoT based mostly Home Automation System"; Advances in Applied Science; Volume 2017; Article ID 100005, pp. 01-06; Feb. 2017
- [12] A. Sharma, J. Mondal, C. Pandey, R. Kumar and A. Bhattacharya, "IoT based mostly Home Automation System victimisation Arduino"; seventh All Bharat put down Engineering school educational Meet - 2016& Innovative Model Competition for a property Society on thirteenth March, 2016; Organized by Forum of Scientists, Engineers & Technologists (FOSET) in association with Supreme data Foundation cluster of establishments, India.